



Cisco Aironet 5-GHz 14-dBi Directional Antenna (AIR-ANT5114P2M-N)

This document outlines the specifications for the Cisco Aironet AIR-ANT5114P2M-N 5-GHz 14-dBi 2-Port Directional antenna with N-type connectors and provides instructions for mounting it. The antenna operates in the 5-GHz frequency band and is designed for use in outdoor environments.

The following information is provided in this document.

- [Technical Specifications, page 2](#)
- [System Requirements, page 3](#)
- [Safety Precautions, page 3](#)
- [Installation Guidelines, page 4](#)
- [Installing the Antenna, page 5](#)
- [Obtaining Documentation and Submitting a Service Request, page 13](#)



Technical Specifications

Antenna type	2-Element Patch Array
Operating frequency range	5150–5900 MHz
Nominal input impedance	50 Ohms
Peak gain	14 dBi
Polarization	Linear, Dual
Elevation plane 3-dB beamwidth	30°
Azimuth plane 3-dB beamwidth	30°
Sidelobe level	< -15 dBc
Front-to-back ratio	> 25 dB
Cable length and type	30 in. (76.2 cm) outdoor rated Coax
Connector type	N Male
Length	7.8 in. (19.8 cm)
Width	7.8 in. (19.8 cm)
Height	1.2 in. (3 cm)
Weight	21.6 oz. (0.61 kg)
Operating temperature range	-40°F to 131°F (-40°C to 55°C)

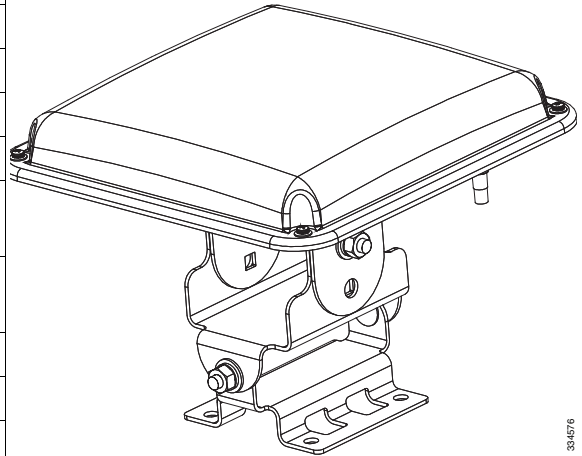

334576

Elevation and Azimuth Plane Patterns

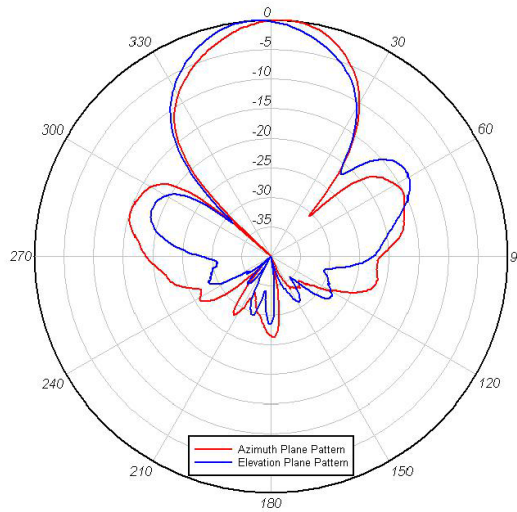

334577

System Requirements

This antenna is designed for use with Cisco Aironet access points and bridges but can be used with any 5-GHz Cisco Aironet radio device that uses an N-male connector.

Safety Precautions



Warning

Installation of this antenna near power lines is dangerous. For your safety, follow the installation directions.



Warning

This warning symbol means danger. You are in a situation that could cause bodily injury. Before you work on any equipment, be aware of the hazards involved with electrical circuitry and be familiar with standard practices for preventing accidents.



Warning

In order to comply with international radio frequency (RF) exposure limits, dish antennas should be located at a minimum of 8.7 inches (22 cm) or more from the bodies of all persons. Other antennas should be located a minimum of 7.9 inches (20 cm) or more from the bodies of all persons.



Warning

Do not work on the system or connect or disconnect cables during periods of lightning activity.



Warning

This equipment must be grounded. Never defeat the ground conductor or operate the equipment in the absence of a suitably installed ground conductor. Contact the appropriate electrical inspection authority or an electrician if you are uncertain that suitable grounding is available.



Warning

Do not locate the antenna near overhead power lines or other electric light or power circuits, or where it can come into contact with such circuits. When installing the antenna, take extreme care not to come into contact with such circuits, as they may cause serious injury or death. For proper installation and grounding of the antenna, please refer to national and local codes (e.g. U.S.:NFPA 70, National Electrical Code, Article 810, in Canada: Canadian Electrical Code, Section 54).

Each year hundreds of people are killed or injured when attempting to install an antenna. In many of these cases, the victim was aware of the danger of electrocution but did not take adequate steps to avoid the hazard.

For your safety, and to help you achieve a good installation, please read and follow these safety precautions. **They may save your life!**

1. If you are installing an antenna for the first time, for your own safety as well as others, seek professional assistance. Your Cisco sales representative can explain which mounting method to use for the size and type antenna you are about to install.
2. Select your installation site with safety, as well as performance in mind. Remember, electric power lines and phone lines look alike. For your safety, assume that any overhead line can kill you.

3. Call your electric power company. Tell them your plans and ask them to come look at your proposed installation. This is a small inconvenience considering your life is at stake.
4. Plan your installation carefully and completely before you begin. Successful raising of a mast or tower is largely a matter of coordination. Each person should be assigned to a specific task and should know what to do and when to do it. One person should be in charge of the operation to issue instructions and watch for signs of trouble.
5. When installing your antenna, remember:
 - a. **Do not** use a metal ladder.
 - b. **Do not** work on a wet or windy day.
 - c. **Do** dress properly—shoes with rubber soles and heels, rubber gloves, long sleeved shirt or jacket.
6. If the assembly starts to drop, get away from it and let it fall. Remember, the antenna, mast, cable, and metal guy wires are all excellent conductors of electrical current. Even the slightest touch of any of these parts to a power line complete an electrical path through the antenna and the installer: **you!**
7. If any part of the antenna system should come in contact with a power line, **do not touch it or try to remove it yourself. Call your local power company.** They will remove it safely.
8. If an accident should occur with the power lines call for qualified emergency help immediately.

Installation Guidelines

Because the antennas transmit and receive radio signals, they are susceptible to RF obstructions and common sources of interference that can reduce throughput and range of the device to which they are connected. Follow these guidelines to ensure the best possible performance:

- Mount the antenna as high as possible to take advantage of its propagation characteristics.
- Keep the antenna away from metal obstructions such as heating and air-conditioning ducts, large ceiling trusses, building superstructures, and major power cabling runs. If necessary, use a rigid conduit to lower the antenna away from these obstructions.
- The density of the materials used in a building's construction determines the number of walls the signal must pass through and still maintain adequate coverage. Consider the following before choosing the location in which to install your antenna:
 - Paper and vinyl walls have very little affect on signal penetration.
 - Solid and pre-cast concrete walls limit signal penetration to one or two walls without degrading coverage.
 - Concrete and wood block walls limit signal penetration to three or four walls.
 - A signal can penetrate five or six walls constructed of drywall or wood.
 - A thick metal wall causes signals to reflect, causing poor penetration.
- Install the antenna away from 5-GHz cordless phones. These products can cause signal interference because they operate in the same frequency range as the device your antenna is connected to.

Site Selection

Before attempting to install your antenna, determine where you can best place the antenna for safety and performance.

Follow these steps to determine a safe distance from wires, power lines, and trees.

-
- Step 1** Measure the height of your antenna.
- Step 2** Add this length to the length of your tower or mast and then double this total for the minimum recommended safe distance.

**Caution**

If you are unable to maintain this safe distance, stop and get professional help.

Generally, the higher an antenna is above the ground, the better it performs. Good practice is to install your antenna about 5 to 10 ft (1.5 to 3 m) above the roof line and away from all power lines and obstructions. If possible, find a mounting place directly above your wireless device so that the lead-in cable can be as short as possible.

Installing the Antenna

You can install the antenna on a pole from 1.63” to 2.3” pipe O.D. The mounting options allow the antenna to be vertically or horizontally polarized.

Tools and Equipment Required

An installation kit is shipped with the antenna and consists of the panel antenna with adjustable mount and hardware, including:

- Antenna mount bracket
- Elevation adjustable bracket
- Azimuth adjustable bracket
- Four 1/4-in. 20x3/4 carriage bolts
- Six 1/4-in. 20 hex nuts
- Six 1/4-in. 20 spring lock washers
- Six 1/4-in. 20 flat washers
- Two pipe clamps

To attach the mount to the antenna and secure it to the pole, you need the following tools and equipment, which are not provided.

- 7/16-in wrench
- 5/16-in nut driver or flat head screwdriver for pipe clamps

The following sections contain typical procedures for installing the antenna on a pole. Your installation may vary. Before you begin, you may want to refer to [Figure 1](#).

Mounting on a Pole

Follow these steps to mount your antenna on a pole.

- Step 1** Remove antenna and mount kit from packaging.
- Step 2** Attach antenna mount bracket to the back of the antenna as shown applying a maximum nut-tightening torque of 55 in-lbf (6.2 Nm).

Figure 1 Attaching Antenna Mount Bracket

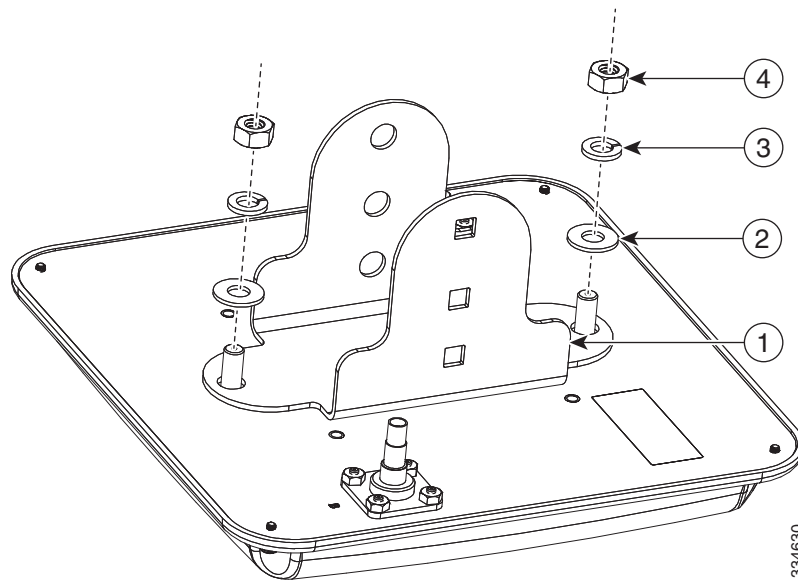

1	Antenna mount bracket	3	1/4-in. spring lock washer
2	1/4-in. flat washer	4	1/4-in. 20 hex nut

- Step 3** Attach elevation adjustable bracket as shown and loosely secure hardware. The carriage bolt square holes must be on the inside.

Figure 2 Attaching Elevation Adjustable Bracket

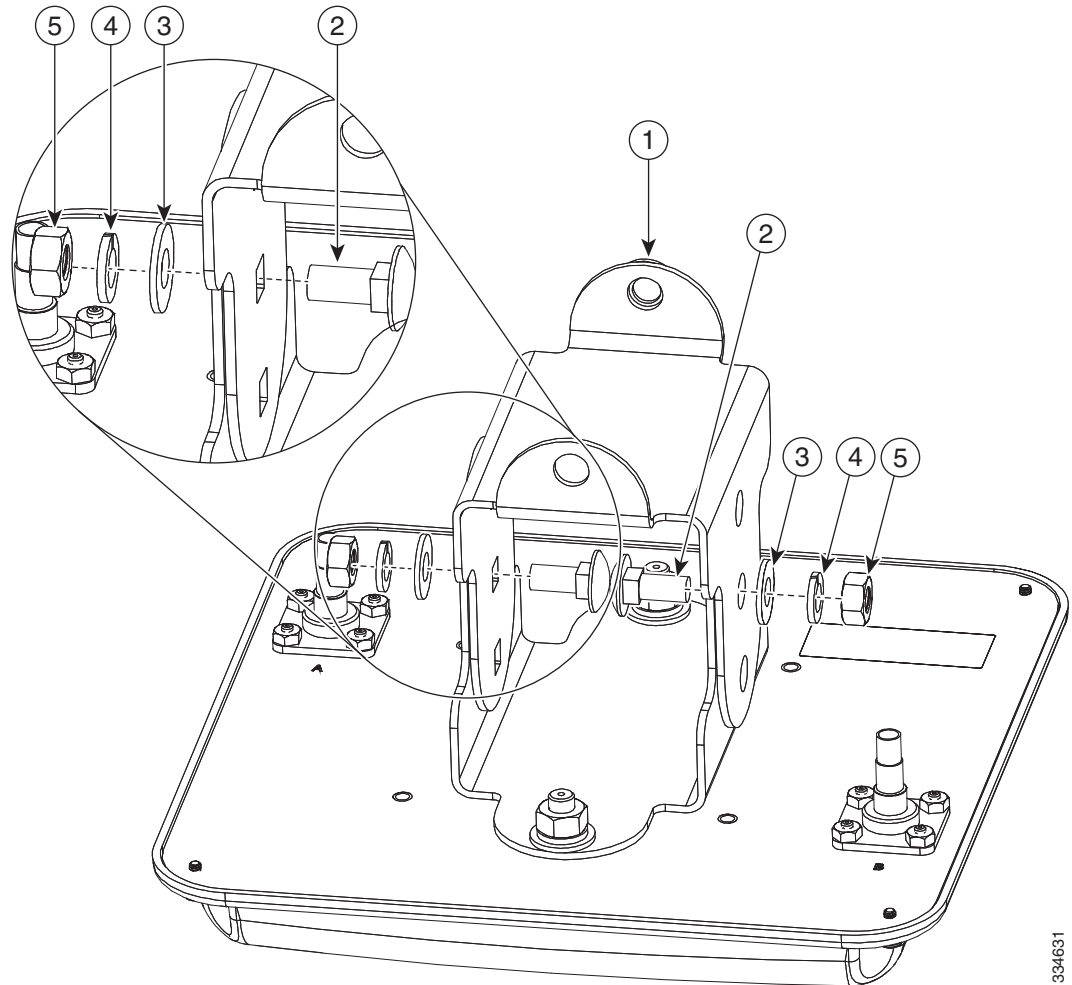

334631

1	Elevation adjustable bracket	4	1/4-in. spring lock washer
2	1/4-in. 20x3/4 carriage bolt	5	1/4-in. 20 hex nut
3	1/4-in. flat washer		

Step 4 Attach azimuth adjustable bracket to pipe routing band clamps as shown. Tighten the pipe clamps to a torque of 43-51 in-lbf (4.9-5.8 Nm).

Figure 3 Attaching Azimuth Adjustable Bracket

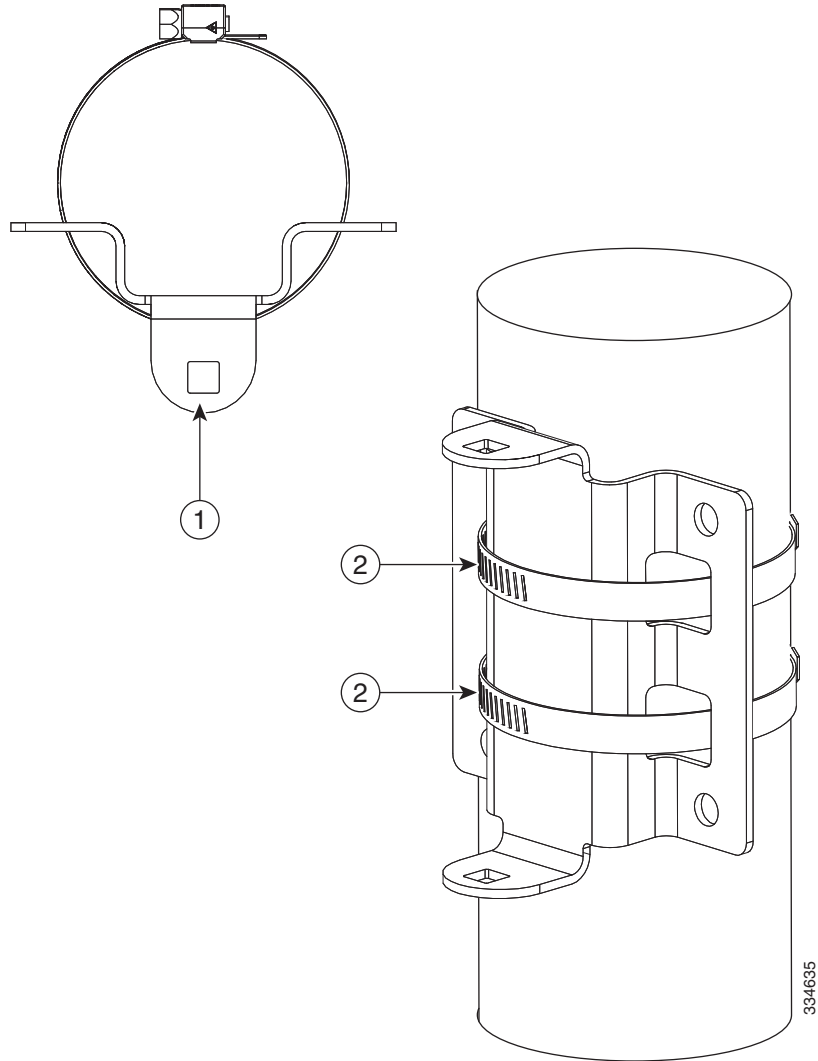

1	Azimuth adjustable bracket	2	Pipe clamps
---	----------------------------	---	-------------

Step 5 Attach antenna assembly to azimuth bracket on pipe.

Figure 4 Attaching Antenna Assembly

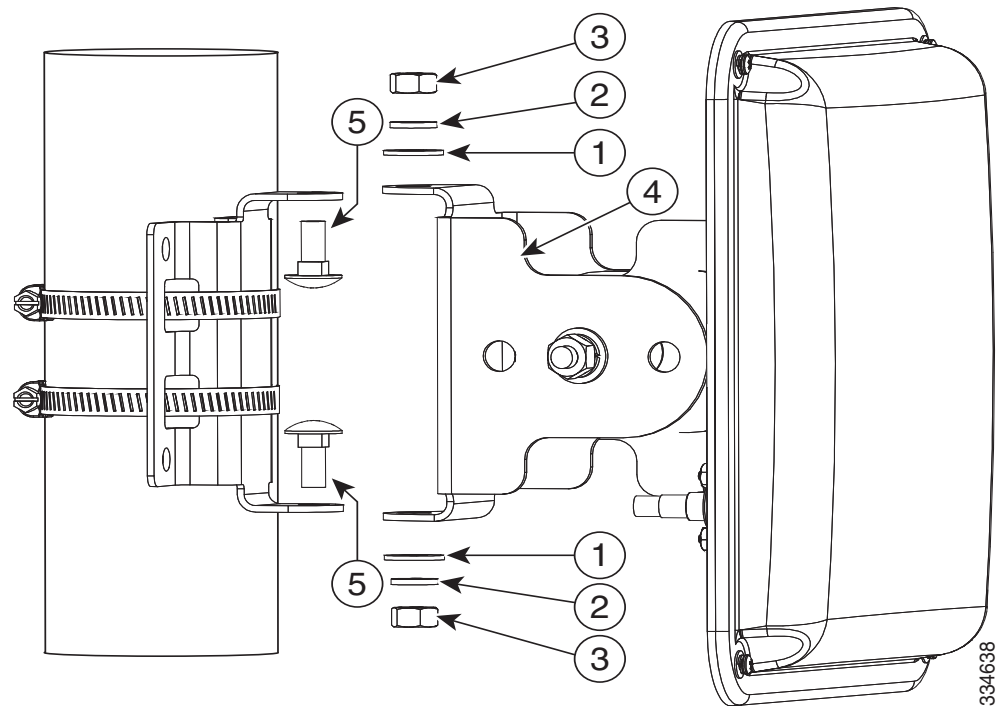

1	1/4-in. flat washer	4	Elevation adjustable bracket
2	1/4-in. spring lock washer	5	1/4-in. 20x3/4 carriage bolt
3	1/4-in. 20 hex nut		

- Step 6** Adjust the position of the antenna to the desired azimuth and elevation angles and tighten all pivot hardware (4 places) to a maximum torque of 55 in-lbf (6.2 Nm). The bracket allows the antenna position to be adjustable to ± 45 degrees azimuth and ± 60 degrees elevation.

Figure 5 *Adjusting Antenna Position*

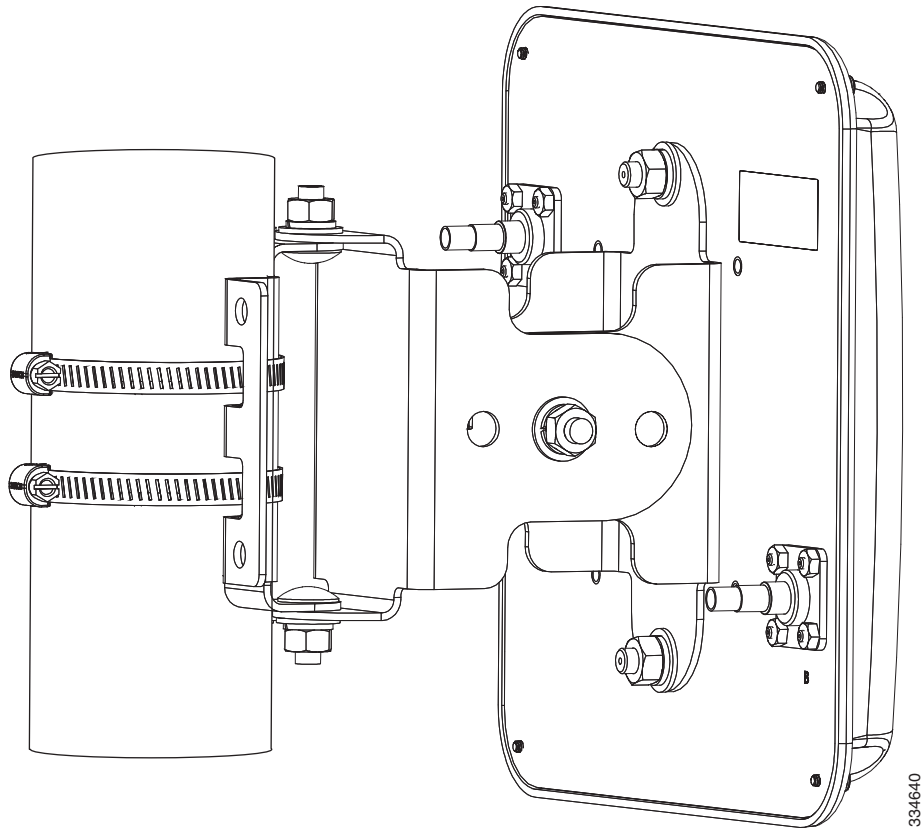

Note

Cisco recommends grounding the antenna. See the [“Grounding the Antenna”](#) section on page 13 for details.

Installing the Optional Mounting Bracket Kit

Using an optional antenna mounting bracket kit, the AIR-ANT5114P2M-N antenna can be mounted directly on an access point in a strand mount or pole mount environment. The antenna bracket kit contains four bracket sections and fasteners that you can assemble in multiple configurations to position and aim the directional antenna in a range of positions. For more information on mounting the antenna with the optional mounting bracket, refer to *Installing Antenna Brackets on Cisco 1550 Series Outdoor Mesh Access Points*.

Mounting on a Vertical Surface

The antenna can be wall mounted. Hardware is not included for wall-mount installation.

Follow these steps to mount your antenna on a vertical surface.

-
- Step 1** Remove antenna and mount kit from packaging.
 - Step 2** Attach antenna mount bracket to the back of the antenna as shown in [Figure 1](#), applying a maximum nut-tightening torque of 55 in-lbf (6.2 Nm).
 - Step 3** Attach elevation adjustable bracket (B) as shown in [Figure 2](#) and loosely secure hardware. The carriage bolt square holes must be on the inside.
 - Step 4** Using the appropriate customer-supplied anchors and screws, attach the azimuth adjustable bracket to the wall as shown:

Figure 6 Wall Mounting

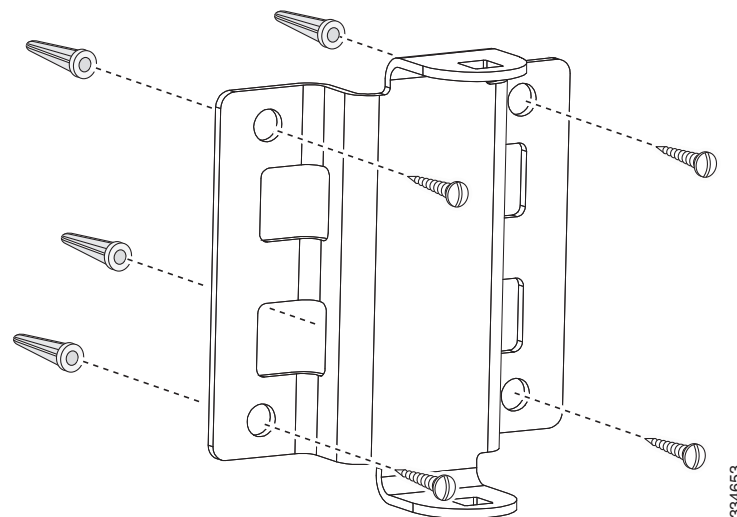

[Figure 7](#) shows, in inches, the distance between the bracket mounting holes.

Figure 7 Distance Between Bracket Mounting Holes

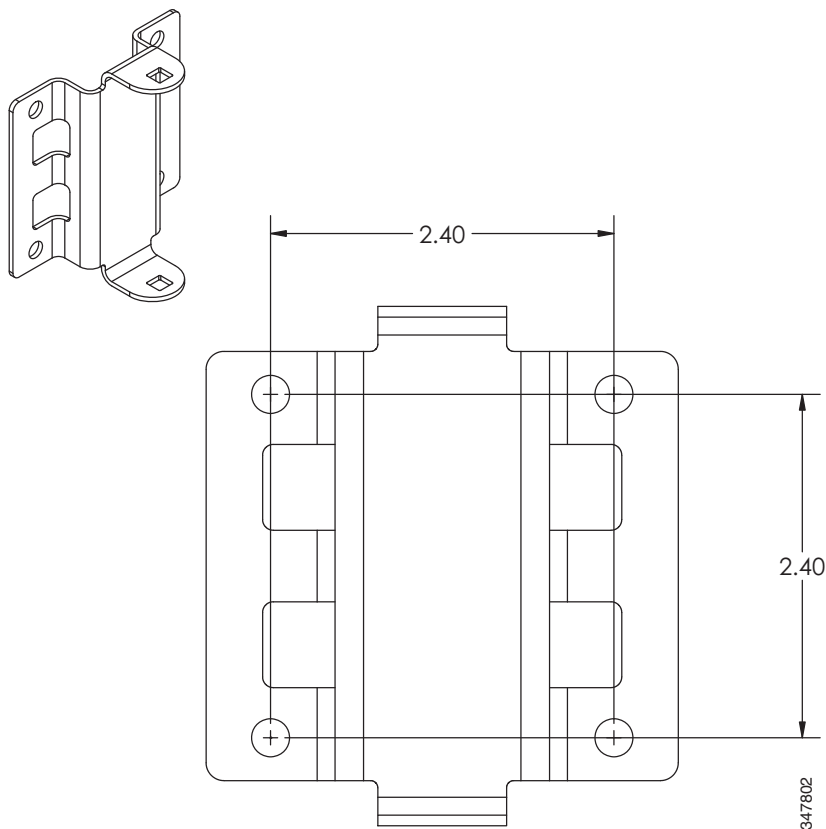

Step 5 Attach antenna assembly to azimuth bracket, as shown in [Figure 4](#).

Step 6 Adjust the position of the antenna to the desired azimuth and elevation angles and tighten all pivot hardware (4 places) to a maximum torque of 55 in-lbf (6.2 Nm). The bracket allows the antenna position to be adjustable to ± 45 degrees azimuth and ± 60 degrees elevation.



Note Cisco recommends grounding the antenna. See the [“Grounding the Antenna”](#) section on page 13 for details.

Antenna Cable Information

If the antenna is used with the Cisco 1552CU or 1552EU access point, the port A of the antenna must be connected to port 1 of the access point, port B of the antenna must be connected to port 3 of the access point, and port 2 of the access point must be capped with the cap enclosed with the antenna.



Note Coaxial cable loses efficiency as the frequency increases, resulting in signal loss. The cable should be kept as short as possible because cable length also causes signal loss (the longer the run, the greater the loss).

**Note**

The antenna cable has a 0.5 in. (12.7 mm) bend radius. Sharply bending or crimping the cable may cause a degradation in performance.

The antenna terminates with an N-male plug after a short, 2.5-ft (0.76-m) cable. The mating connector to the antenna is an appropriate N-female jack. The connector on the opposite end will vary according to the type of equipment used.

After the cable is attached to the antenna, make sure that the connections are sealed (if outdoors) to prevent moisture and other weathering elements from affecting performance. Cisco recommends using a coax seal (such as CoaxSeal) for outdoor connections. Silicone sealant or electrical tape are **not** recommended for sealing outdoor connections.

Grounding the Antenna

Follow these steps to ground the antenna in accordance with national electrical code instructions.

- Step 1** Use No. 10 AWG copper or No. 8 or larger copper-clad steel or bronze wire as ground wires for both mast and lead-in. Securely clamp the wire to the bottom of the mast.
- Step 2** Secure the lead-in wire to an antenna discharge unit and the mast ground wire to the building with stand-off insulators spaced from 4 ft (1.2 m) to 8 ft (2.4 m) apart.
- Step 3** Mount the antenna discharge unit as close as possible to where the lead-in wire enters the building.
- Step 4** Drill a hole in the building's wall as close as possible to the equipment to which you will connect the lead-in cable.

**Caution**

There may be wires in the wall. Make sure your drilling location is clear of any obstructions or other hazards.

- Step 5** Pull the cable through the hole and form a drip loop close to where it enters the building.
- Step 6** Thoroughly waterproof the lead-in area.
- Step 7** Install a lightning arrester.
- Step 8** Connect the lead-in cable to the equipment.

Obtaining Documentation and Submitting a Service Request

For information on obtaining documentation, submitting a service request, and gathering additional information, see *What's New in Cisco Product Documentation* at:

<http://www.cisco.com/en/US/docs/general/whatsnew/whatsnew.html>.

Subscribe to *What's New in Cisco Product Documentation*, which lists all new and revised Cisco technical documentation, as an RSS feed and deliver content directly to your desktop using a reader application. The RSS feeds are a free service.

Cisco and the Cisco logo are trademarks or registered trademarks of Cisco and/or its affiliates in the U.S. and other countries. To view a list of Cisco trademarks, go to this URL: www.cisco.com/go/trademarks. Third-party trademarks mentioned are the property of their respective owners. The use of the word partner does not imply a partnership relationship between Cisco and any other company. (1110R)

Copyright © 2012-2013 Cisco Systems, Inc. All rights reserved.